



## 2 Bed House - Terraced

3 King Street, Duffield, Belper DE56 4EU  
£975 Per Calendar Month



Fletcher  
& Company

[www.fletcherandcompany.co.uk](http://www.fletcherandcompany.co.uk)

- OUTSTANDING LOCATION
- NEWLY FITTED KITCHEN AND BATHROOM
- LOW MAINTENANCE/ PRIVATE REAR GARDEN
- NEW CARPETS
- RE-DECORATED THROUGHOUT
- AVAILABLE END OF MARCH 2026
- EPC D
- COUNCIL TAX B
- STUNNING PROPERTY
- FEELS NEW THROUGHOUT

This is a stunning two-bedroom mid-terrace property that has just been redecorated throughout and has a newly fitted kitchen and bathroom.

This extremely attractive mid-terrace cottage is situated in a desirable and convenient location within walking distance of all local amenities and within the noted Ecclesbourne School catchment area. The property has the advantage of gas fired central heating and comprises: Entrance Hall, Lounge with feature fireplace, Dining Area/Fitted Kitchen with new fridge/freezer and washer/dryer, Shower Room, Two bedrooms.

This property is situated within yards of the vast and ever growing local amenities that Duffield has to offer, along with the nearby train station, bus routes and close to major road networks.

Ground Floor - The property can be entered via a secure wooden door to the front aspect opening to:

Entrance Hallway - With stairs leading to the first floor, a central heating radiator and tiled floor

Living Room - A really warm feeling area with a fully functioning log burning fire.

Kitchen/Dining room - Newly fitted, benefits from an integral washer/dryer, fridge/ freezer and plenty of storage space

Storage area - leading to the side door and shower room

Shower room - a beautifully fitted room with an extremely generously sized shower area.

First Floor - stairs from the kitchen/diner

Master bedroom - situated at the front of the property, a generous size with plenty of cloth hanging space.

Second bedroom - suitable for a single bed or a great space for an office or similar

## Outside

Access to the private and self-contained garden area, the garden benefits from a patio area as well as artificial grass being laid. This makes a perfect place to sit and relax with privacy, in a low-maintenance garden that benefits from being south-facing.

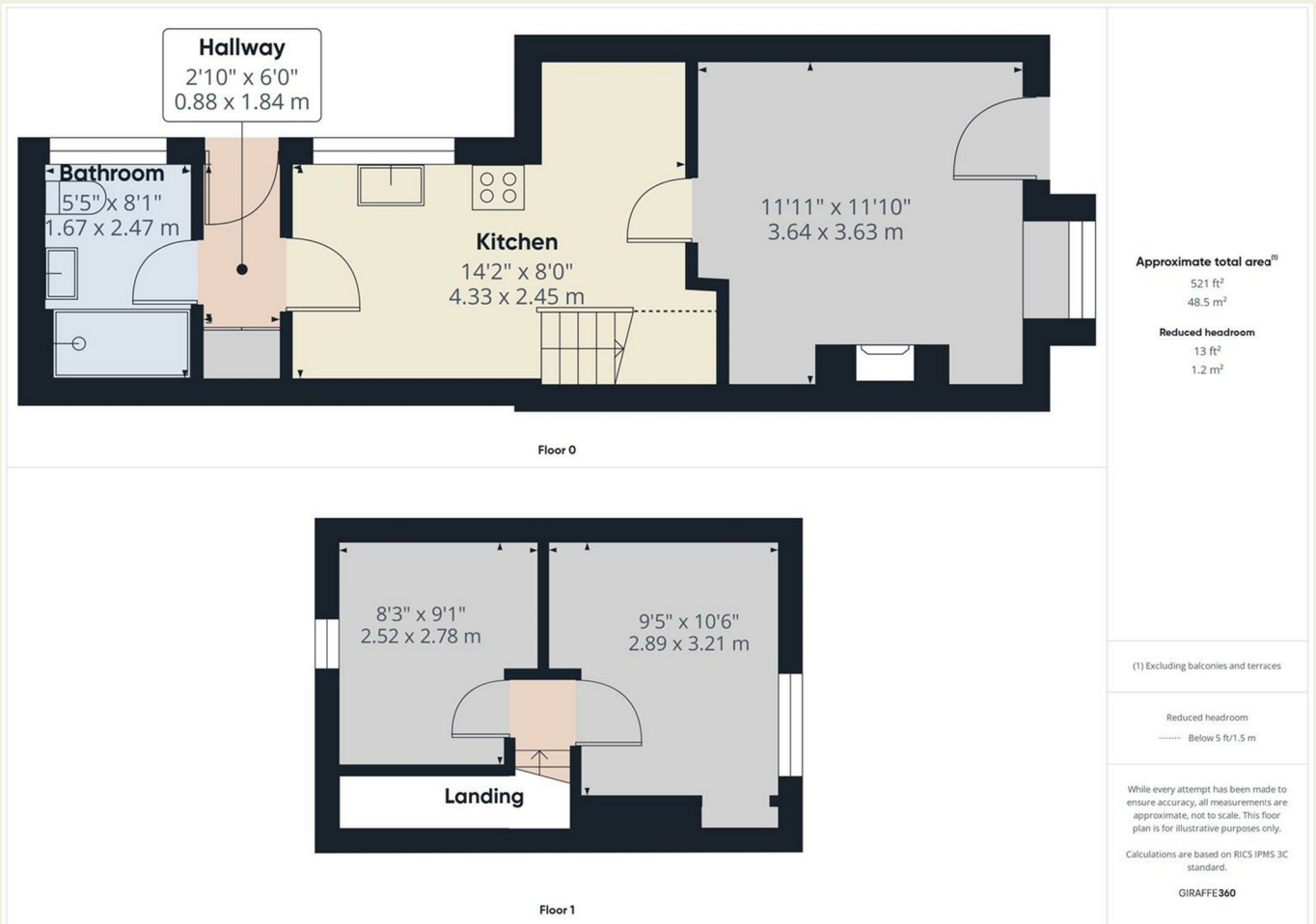

These particulars do not constitute an offer or a contract neither do they form part of an offer or contract. The vendor does not make or give and Messrs. Fletcher & Company nor any person employed has any authority to make or give any representation or warranty, written or oral, in relation to this property. Whilst we endeavour to make our sales details accurate and reliable, if there is any point which is of particular importance to you, please contact the office and we will be pleased to check the information for you, particularly if contemplating travelling some distance to view the property. None of the services or appliances to the property have been tested and any prospective purchasers should satisfy themselves as to their adequacy prior to committing themselves to purchase.

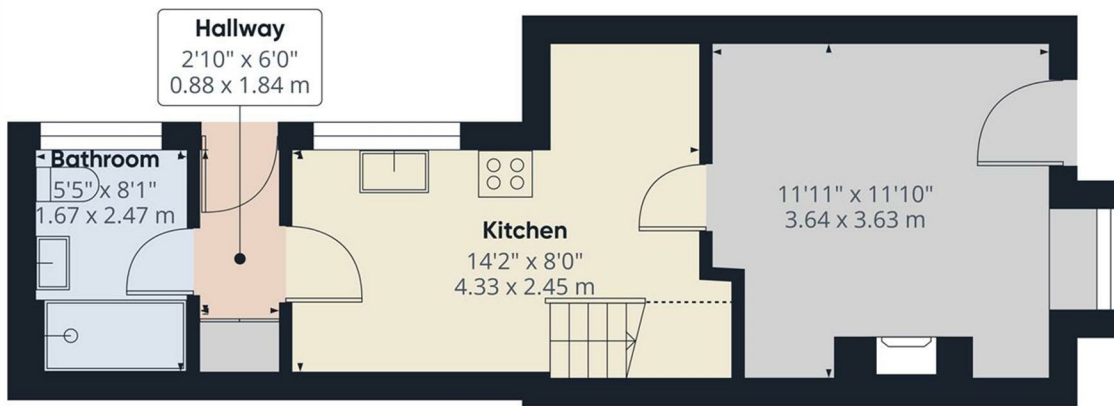

**Approximate total area<sup>m</sup>**  
 348 ft<sup>2</sup>  
 32.4 m<sup>2</sup>

**Reduced headroom**  
 13 ft<sup>2</sup>  
 1.2 m<sup>2</sup>

(1) Excluding balconies and terraces

Reduced headroom  
 ----- Below 5 ft/1.5 m

While every attempt has been made to ensure accuracy, all measurements are approximate, not to scale. This floor plan is for illustrative purposes only.

Calculations are based on RICS IPMS 3C standard.

**GIRAFFE360**

Floor 0

These particulars do not constitute an offer or a contract neither do they form part of an offer or contract. The vendor does not make or give and Messrs. Fletcher & Company nor any person employed has any authority to make or give any representation or warranty, written or oral, in relation to this property. Whilst we endeavour to make our sales details accurate and reliable, if there is any point which is of particular importance to you, please contact the office and we will be pleased to check the information for you, particularly if contemplating travelling some distance to view the property. None of the services or appliances to the property have been tested and any prospective purchasers should satisfy themselves as to their adequacy prior to committing themselves to purchase.

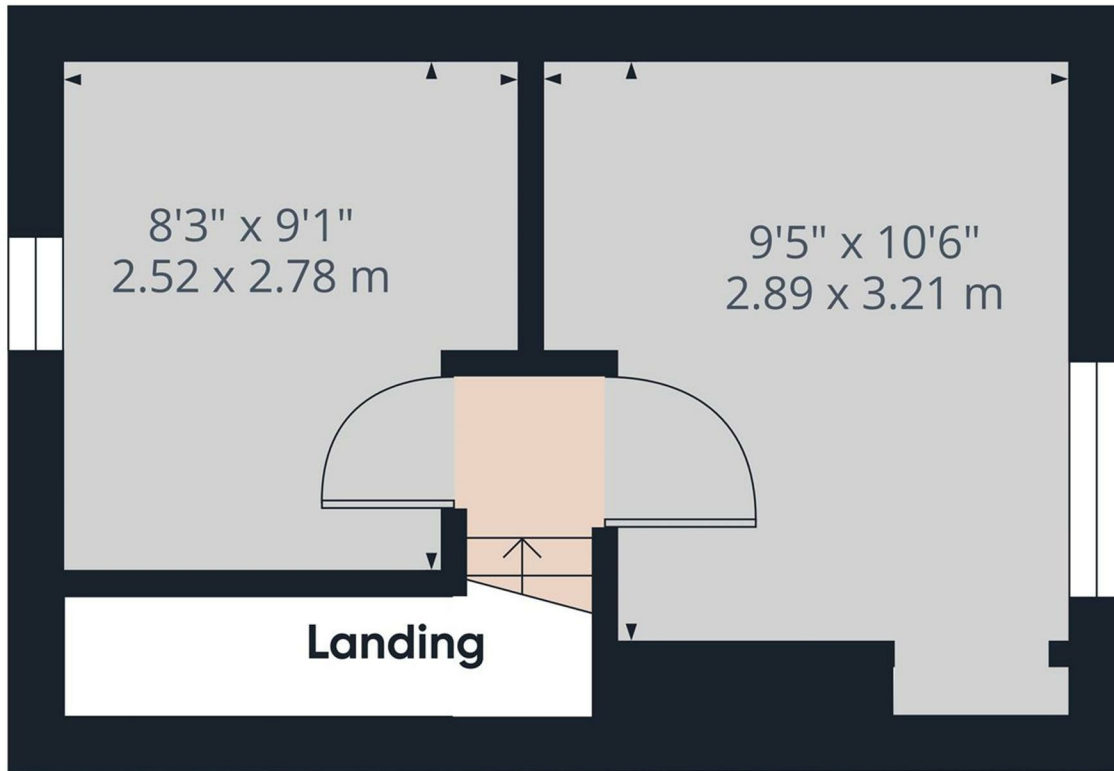

Approximate total area<sup>m</sup>  
 173 ft<sup>2</sup>  
 16.1 m<sup>2</sup>

(1) Excluding balconies and terraces

While every attempt has been made to ensure accuracy, all measurements are approximate, not to scale. This floor plan is for illustrative purposes only.

Calculations are based on RICS IPMS 3C standard.

GIRAFFE360

Floor 1

### Energy Efficiency Rating

	Current	Potential
<i>Very energy efficient - lower running costs</i>		
(92 plus) <b>A</b>		
(81-91) <b>B</b>		
(69-80) <b>C</b>		
(55-68) <b>D</b>		
(39-54) <b>E</b>		
(21-38) <b>F</b>		
(1-20) <b>G</b>		
<i>Not energy efficient - higher running costs</i>		
	<b>62</b>	<b>87</b>
<b>England &amp; Wales</b>	EU Directive 2002/91/EC	

### Environmental Impact (CO<sub>2</sub>) Rating

	Current	Potential
<i>Very environmentally friendly - lower CO<sub>2</sub> emissions</i>		
(92 plus) <b>A</b>		
(81-91) <b>B</b>		
(69-80) <b>C</b>		
(55-68) <b>D</b>		
(39-54) <b>E</b>		
(21-38) <b>F</b>		
(1-20) <b>G</b>		
<i>Not environmentally friendly - higher CO<sub>2</sub> emissions</i>		
<b>England &amp; Wales</b>	EU Directive 2002/91/EC	

These particulars do not constitute an offer or a contract neither do they form part of an offer or contract. The vendor does not make or give and Messrs. Fletcher & Company nor any person employed has any authority to make or give any representation or warranty, written or oral, in relation to this property. Whilst we endeavour to make our sales details accurate and reliable, if there is any point which is of particular importance to you, please contact the office and we will be pleased to check the information for you, particularly if contemplating travelling some distance to view the property. None of the services or appliances to the property have been tested and any prospective purchasers should satisfy themselves as to their adequacy prior to committing themselves to purchase.